



Profit from the Eagle Advantage®

Specification Sheet

Short Form Specifications

Eagle Q-Lever™ Cantilever Add-On Shelving, model _____, 4-Tier add-on units feature one 76"-high upright and all-wire shelves. Maximum accessibility and productivity. No wall bolting required. Upright utilizes adjustment in 2" increments without the use of tools. Shelves offered with Valu-Master® gray or Valu-Gard® green epoxy finish. Valu-Master® gray epoxy on upright.



Options / Accessories

- Wall Grids
- Hanger Rails
- Supply Bins
- Storage Baskets
- 36", 56", 66", or 86" optional height.

EAGLE GROUP

100 Industrial Boulevard, Clayton, DE 19938-8903 USA
 Phone: 302-653-3000 • Fax: 302-653-2065
www.eaglegrp.com

Foodservice Division: Phone 800-441-8440

MHC/Retail Display Divisions: Phone 800-637-5100

For custom configuration or fabrication needs, contact our SpecFAB® Division.
 Phone: 302-653-3000 • Fax: 302-653-2065 • e-mail: quotes@eaglegrp.com

Item No.: _____
 Project No.: _____
 S.I.S. No.: _____

Q-LEVER™ Cantilever Shelving— 4-Tier Add-On Units with Wire Shelves, 76" Height

MODELS:

- | | | | |
|---------------------------------|---------------------------------|---------------------------------|---------------------------------|
| <input type="checkbox"/> Q1824* | <input type="checkbox"/> Q2124* | <input type="checkbox"/> Q2424* | <input type="checkbox"/> Q3030* |
| <input type="checkbox"/> Q1830* | <input type="checkbox"/> Q2130* | <input type="checkbox"/> Q2430* | <input type="checkbox"/> Q3036* |
| <input type="checkbox"/> Q1836* | <input type="checkbox"/> Q2136* | <input type="checkbox"/> Q2436* | <input type="checkbox"/> Q3042* |
| <input type="checkbox"/> Q1842* | <input type="checkbox"/> Q2142* | <input type="checkbox"/> Q2442* | <input type="checkbox"/> Q3048* |
| <input type="checkbox"/> Q1848* | <input type="checkbox"/> Q2148* | <input type="checkbox"/> Q2448* | <input type="checkbox"/> Q3054* |
| <input type="checkbox"/> Q1854* | <input type="checkbox"/> Q2154* | <input type="checkbox"/> Q2454* | <input type="checkbox"/> Q3060* |
| <input type="checkbox"/> Q1860* | <input type="checkbox"/> Q2160* | <input type="checkbox"/> Q2460* | <input type="checkbox"/> Q3066* |
| <input type="checkbox"/> Q1866* | <input type="checkbox"/> Q2166* | <input type="checkbox"/> Q2466* | <input type="checkbox"/> Q3072* |
| <input type="checkbox"/> Q1872* | <input type="checkbox"/> Q2172* | <input type="checkbox"/> Q2472* | |

* See charts on back page for complete model numbers.

Design & Construction Features

- Includes one 76" upright, two braces, four wire shelves, three pairs of brackets, X-brace assembly, and hardware.
- Cantilevered design improves accessibility and productivity.
- Wall bolting not required.
- Upright utilizes 2" adjustment for shelf and accessory spacing.
- Shelves and accessories can be easily adjusted without tools
- Shelves can be added to the left or right of an existing unit.
- Sizing available:
 - Widths: 18"; 21"; 24"; 30"
 - Lengths: 24"; 30"; 36"; 42"; 48"; 54"; 60"
 - Height (standard): 76"
- Choice of Valu-Master® gray or Valu-Gard® green epoxy finish on the shelves.
- Valu-Master® gray epoxy finish on upright.

Certifications / Approvals



AutoQuotes



Spec sheets available for viewing, printing or downloading from our online literature library at www.eaglegrp.com

Eagle Foodservice Equipment, Eagle MHC, SpecFAB®, and Retail Display are divisions of Eagle Group. ©2018 by the Eagle Group



Item No.: _____
 Project No.: _____
 S.I.S. No.: _____

Q-LEVER™ Shelving—4-Tier Add-Ons with Wire Shelves, 76" Height

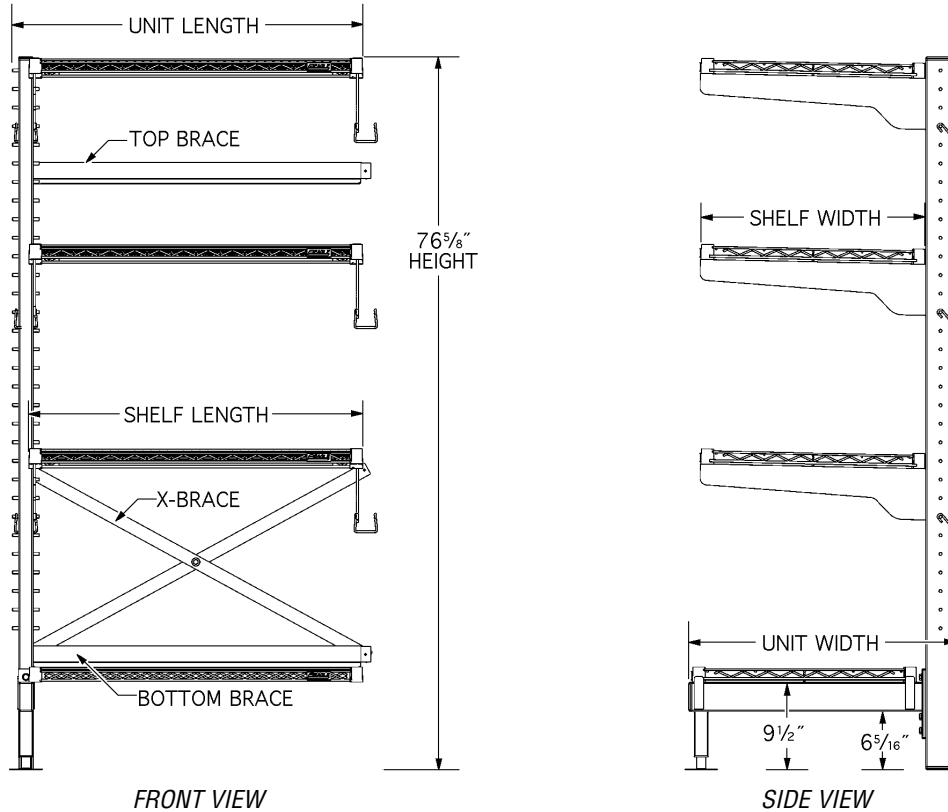

shelf length in. mm	unit** length in. mm	...WITH 18" (457mm)- WIDE SHELVES *		...WITH 21" (533mm)- WIDE SHELVES *		...WITH 24" (610mm)- WIDE SHELVES *		...WITH 30" (762mm)- WIDE SHELVES *	
		Shelves with Valu-Master® finish	Shelves with Valu-Gard® finish	Shelves with Valu-Master® finish	Shelves with Valu-Gard® finish	Shelves with Valu-Master® finish	Shelves with Valu-Gard® finish	Shelves with Valu-Master® finish	Shelves with Valu-Gard® finish
24" 610	25 1/2" 648	Q1824V76A-4	Q1824VG76A-4	Q2124V76A-4	Q2124VG76A-4	Q2424V76A-4	Q2424VG76A-4	-	-
30" 762	31 1/2" 800	Q1830V76A-4	Q1830VG76A-4	Q2130V76A-4	Q2130VG76A-4	Q2430V76A-4	Q2430VG76A-4	Q3030V76A-4	Q3030VG76A-4
36" 914	37 1/2" 953	Q1836V76A-4	Q1836VG76A-4	Q2136V76A-4	Q2136VG76A-4	Q2436V76A-4	Q2436VG76A-4	Q3036V76A-4	Q3036VG76A-4
42" 1067	43 1/2" 1105	Q1842V76A-4	Q1842VG76A-4	Q2142V76A-4	Q2142VG76A-4	Q2442V76A-4	Q2442VG76A-4	Q3042V76A-4	Q3042VG76A-4
48" 1219	49 1/2" 1257	Q1848V76A-4	Q1848VG76A-4	Q2148V76A-4	Q2148VG76A-4	Q2448V76A-4	Q2448VG76A-4	Q3048V76A-4	Q3048VG76A-4
54" 1372	55 1/2" 1410	Q1854V76A-4	Q1854VG76A-4	Q2154V76A-4	Q2154VG76A-4	Q2454V76A-4	Q2454VG76A-4	Q3054V76A-4	Q3054VG76A-4
60" 1524	61 1/2" 1562	Q1860V76A-4	Q1860VG76A-4	Q2160V76A-4	Q2160VG76A-4	Q2460V76A-4	Q2460VG76A-4	Q3060V76A-4	Q3060VG76A-4
66" 1676	67 1/2" 1715	Q1866V76A-4	Q1866VG76A-4	Q2166V76A-4	Q2166VG76A-4	Q2466V76A-4	Q2466VG76A-4	Q3066V76A-4	Q3066VG76A-4
72" 1829	73 1/2" 1867	Q1872V76A-4	Q1872VG76A-4	Q2172V76A-4	Q2172VG76A-4	Q2472V76A-4	Q2472VG76A-4	Q3072V76A-4	Q3072VG76A-4

* For unit width, add 5 inches to shelf width.
 ** Dimensions are nominal.

EAGLE GROUP
 100 Industrial Boulevard, Clayton, DE 19938-8903 USA
 Phone: 302-653-3000 • Fax: 302-653-2065 • www.eaglegrp.com

Foodservice Division: Phone 800-441-8440
 MHC/Retail Display Divisions: Phone 800-637-5100

Printed in U.S.A.
 ©2018 by Eagle Group
 Rev. 06/18

Spec sheets available for viewing, printing or downloading from our online literature library at www.eaglegrp.com

Although every attempt has been made to ensure the accuracy of the information provided, we cannot be held responsible for typographical or printing errors. Information and specifications are subject to change without notice. Please confirm at time of order.