

# Roll Bag Holders

## ASSEMBLY INSTRUCTIONS

### CAUTION

INSPECT CONTENTS IMMEDIATELY AND FILE CLAIM WITH DELIVERING CARRIER FOR ANY DAMAGE.

**SAVE YOUR BOX AND ALL PACKING MATERIALS.**

YOU ARE RESPONSIBLE FOR DAMAGE TO YOUR UNIT IF RETURNED IMPROPERLY PACKED.

### Parts List

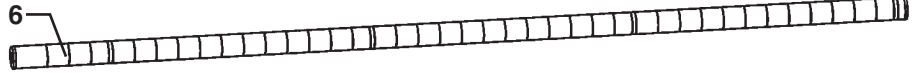
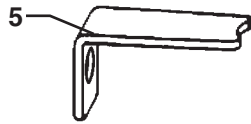
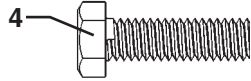
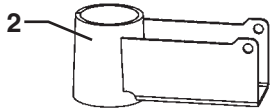
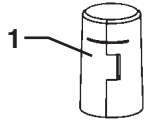

Item #	qty	description
1	1	bag of four split sleeves
2	2	hanger bracket
3	2	hair pin cotter
4	2	hex-head bolt
5	2	bar clip
6	1	roll tube

### Step 1 - Snap split sleeves to rear posts of unit.

Attach split sleeves where roll holder is to be located. The thicker part of the split sleeves goes toward the bottom.

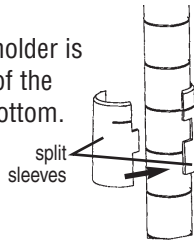

### Step 2 - Attach hanger brackets to split sleeves.

With hanger brackets facing each other, slide each bracket down posts and onto split sleeves.

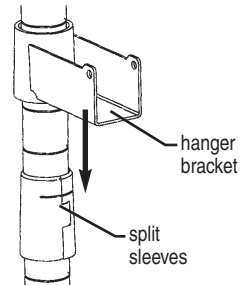

### Step 3 - Attach clips to roll tube.

**IMPORTANT:** Test-fit and place rolls onto roll tube **BEFORE** attaching clips.

Use 5/8" wrench or socket to tighten bolts.

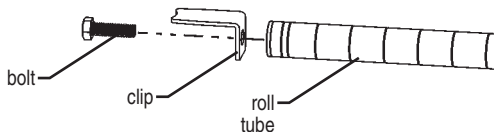

### Step 4 - Install roll tube assembly to hanger brackets.

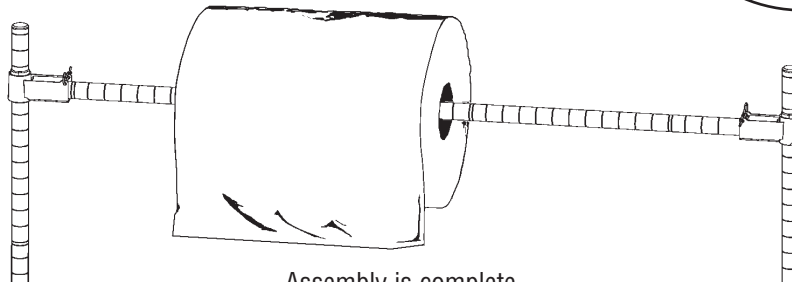
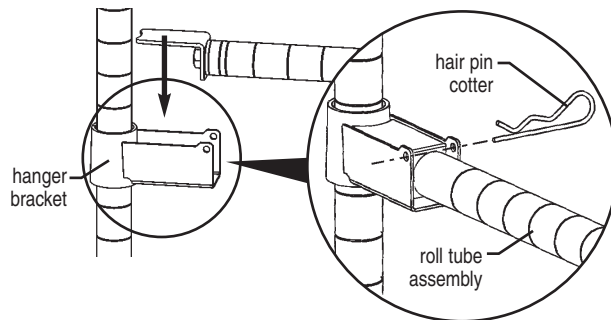

Assembly is complete.

(End)

EG10092 Revised 07/08

**EAGLE**  
GROUP

Profit from the Eagle Advantage®

• 100 Industrial Boulevard, Clayton, Delaware 19938-8903 U.S.A. • [www.eaglegrp.com](http://www.eaglegrp.com)  
• Phone: 302/653-3000 • (Foodservice) 800/441-8440 • (MHC/Retail) 800/637-5100  
• Fax: 302/653-2065

Eagle Foodservice Equipment, Eagle MHC, SpecFAB®, and Retail Display are divisions of Eagle Group. ©2008 by the Eagle Group