



Cleanroom & Lab Solutions

EAGLETM
MHC Division

Material Handling, Healthcare & Cleanroom Equipment



single
(shown with optional hangers)



double
(shown with optional hangers)



cantilevered
(shown with optional hangers)

Gowning Racks - with Hanger Rail

These racks are designed for efficient storage of garments in the cleanroom. Available in stainless steel or electropolished finishes. The stainless steel construction offers a non-contaminating surface that eliminates particle shedding. The electropolished models feature electrochemically passivated surfaces, for the most demanding requirements. 24" width, 75" height, and available in 48" to 84" lengths. Hanger slots are standard 3" centers. Other center configurations are available.



hanger slots on
standard 2½" centers
(shown with optional hangers)

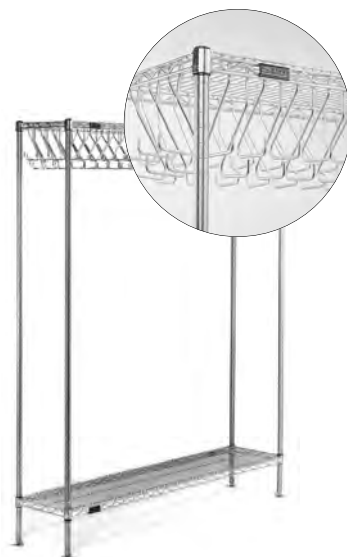

hooks welded on standard 1½" centers
on all four shelf sides

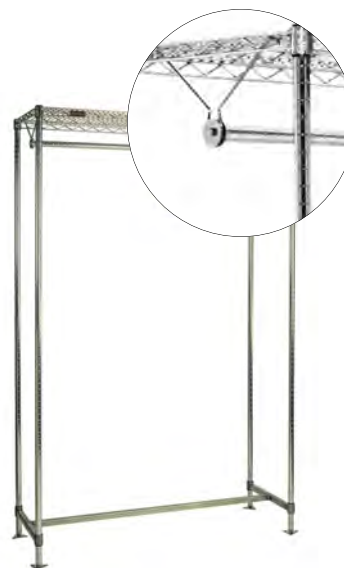

1"-diameter tubular bar
mounted underneath wire shelf

Gowning Racks - with Wire Shelving Components patented QuadTruss[®] design

These racks incorporate standard wire shelving featuring patented QuadTruss[®] design, with specially designed gown storage options. They offer a more economical rack option in less demanding environments. Available in chrome-plated steel as well as electropolished and stainless steel models. Available in 14" and 24" widths, and 48" to 72" lengths. 86" height.

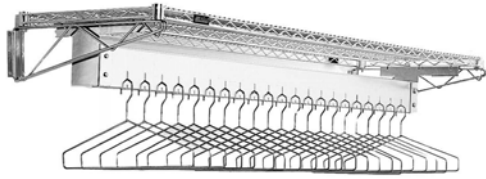

rack with hanger slots
(shown with optional hangers)



rack with hanger tube



rack with hooks

Wall-Mounted Gowning Racks 'Space Management Solutions'

Racks with Hanger Slots

This gowning rack is available in lengths of 48" [17 hangers], 60" [22 hangers], or 72" [27 hangers] and width of 24". Wall mounted, and includes open wire top shelf for laminar flow. Available in electropolished stainless steel or chrome finish. Hangers are optional.

Racks with Hanger Tube

Like the freestanding model, this model features a 1" diameter tubular bar which mounts easily to underside of wire shelf and comes in width of 18" and lengths of 48", 60", and 72". Wire design facilitates laminar flow. Available in electropolished or chrome finish.

Racks with Hooks

This compact design is 14" in width and comes in lengths of 48" [30 hooks], 60" [38 hooks] or 72" [46 hooks]. Available in electropolished or chrome finish.

Hangers and Hanger Bar Kits

Open Loop Hangers

For all gowning rack models that employ hangers. Available in chrome, brush finish, or electropolished stainless steel.

Two-Piece Hangers

For use with non-removable hanger models. The top component is affixed to the gowning rack, while the bottom component is removable for convenient mounting of the garment. Available in chrome, brush finish, or electropolished stainless steel.

Closed Loop Hangers

For use with tubular gowning racks. Hangers are not removable from rack. Available in chrome, brush finish, or electropolished stainless steel.

Slanted Hanger Bar Kits

Used to retrofit existing shelving into freestanding or wall-mounted gowning racks. Hanger slots on 2½" centers. 24" shelf width required. Available in chrome, brush finish, or electropolished stainless steel.

Tubular Hanger Bar Kits

Rack employs both closed loop hangers and open loop hangers. Available in stainless steel and chrome. Width 18", and length ranges from 48" to 72".

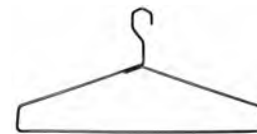

open loop hanger

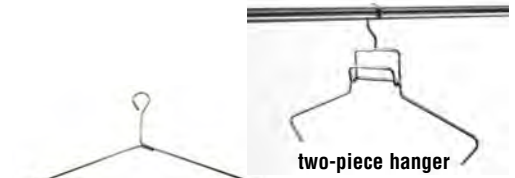

two-piece hanger



closed loop hanger



tubular hanger bar kits
(shown with optional hangers)

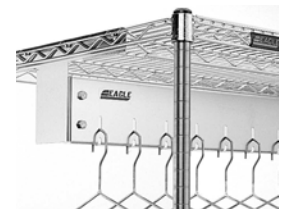

slanted hanger bar kits
(shown with optional hangers)



solid gowning bench



**gowning bench with standard undershelf
(shown with optional additional shelf and dividers)**

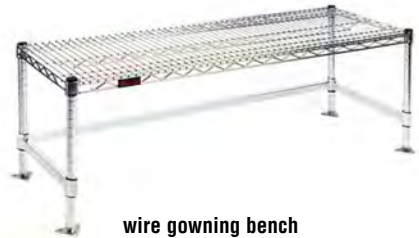

wire gowning bench

Gowning Benches

Solid Gowning Bench

Heavy-duty benches include flanged stainless steel foot plates for convenient attachment to the floor. Available in brushed 304 stainless steel or electropolished finish. Widths of 9" and 12", lengths up to 84", and height of 17".

Gowning Bench with Undershelf Storage

Available with perforated or solid seat. Wire undershelves offer optional bootie storage. These units come complete with designated seat, legs, foot plates, and one wire undershelf (*additional wire shelves and dividers are optional*). Available in electropolished or stainless steel finish. Seating area is 18" wide, and wire undershelf is 14" wide. Length up to 72" and height of 19".

Wire Gowning Bench

Economical gowning bench with wire shelving components offers 62% laminar flow. Ideal for less demanding environments or for use during construction as the room is brought into clean. All units feature four 18" legs with foot plates, one three-sided channel frame, and one wire shelf. 14" width, 18" height, and available in lengths up to 72".

Carts and Wire Shelving Units

patented
QuadTruss®
design

Open wire construction promotes higher visibility and permits greater air circulation, which reduces dust and contamination build-up. QuadTruss® design makes shelves up to 25% stronger. Posts are numbered on vertical 1" increments to ensure, fast, level assembly of shelves and maximum flexibility for unit/cart configuration. Numerous sizes and combinations are available. Accessories available include dividers, ledges, label holders, enclosure panels, and more.



two-shelf utility cart



wire shelving unit



angled wire shelf cart



stainless utility carts



NEW

Stainless Utility Carts

Ideal for light- to medium-duty transport in virtually any environment. Three stainless steel shelves welded to angle legs and caster channel frame. Four 4"-diameter swivel plate casters. 1"-diameter handle on one end. Available with standard 1"-high upturn on ends and rear of top and center shelves, or 1"-high upturn on all sides of all shelves.



PATENTED!
(Patent #7,992,731)

NSF Quad-Adjust® Wire Shelving



channel of shelf corner fits into slot of collar attached to split sleeve

Add to your existing shelving without having to disassemble the entire unit.

Assembly is a simple 3-step exercise:



Step 1
Snap the split sleeves onto a post over the number of your choice.



Step 2
Attach the QuadAdjust® slotted collar onto the split sleeves.



Step 3
Slide shelf into slotted collar to complete.

- Shelves feature special interlocking corners that fit in slots of collars mounted to split sleeves, allowing addition or removal of a shelf without the need to disassemble the entire shelf unit.
- Tapered split sleeves create a positive lock that becomes stronger as the load increases.
- Leveling feet are provided to help compensate for uneven floor surfaces.
- Shelf utilizes a pincer-type design with the mat wire sandwiched between the two top truss wires, adding significant strength and distributing the entire load without stress and strain on the welds.
- Available in standard finishes.
- Accommodates standard wire shelving accessories.

patented QuadTruss® design

(Patent #5,390,803)

QuadPLUS® Polymer Shelf Mats RFID-Compatible!

Mats come with choice of...



Quad-Adjust® Truss Frame...
Allows the addition or removal of a shelf without having to disassemble the entire shelf unit.



...or Standard Wire Truss Frame



shelf mats—blue, louvered and solid
—shown assembled to shelf unit

Blue or green polymer shelf mats available!

Mats snap in place!



removable shelf mats shown with Quad-Adjust® wire truss frame



green louvered shelf mats shown assembled to shelf unit

Easy Assembly! No tools needed!

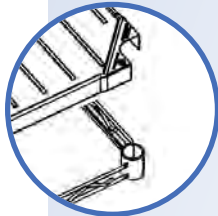

Step 1
Position polymer mats onto wire truss frame or shelf accordingly.

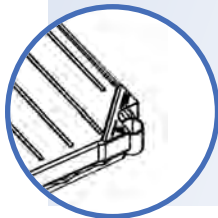

Step 2
Gently push each mat down along the front and rear to snap them into place.



- Mats snap into truss frame
- Injection-molded polypropylene mats feature MICROGARD® antimicrobial protection
- Easy cleaning
- Dishwasher-safe
- Truss frames coated with chrome or Valu-Master® gray epoxy finish (other finishes available, consult factory)
- Both style of truss frames can be fitted onto the same shelf unit
- Set of four split sleeves (included with each truss frame) snap onto Eagle's 1" diameter posts
- Temperature rating of shelf mats: -20°F to 125°F

MICROGARD®

is an antimicrobial agent which contains built-in protection to retard the growth of a broad range of bacteria, mold and mildew on shelf surface that causes stains, odors and degradation.

Standard on all QuadPLUS®



louvered shelf mat



solid shelf mat



vertical storage cabinets

Vertical Storage Cabinets

Features 18-gauge stainless steel cabinet body. Three shelves are adjustable on 4" vertical centers, double pan 20-gauge stainless steel hinged doors, and transverse rod handles featuring keyed locks are standard. Available in 36" and 48" lengths. Flat top or slanted top models available. Optional 5" plate casters with brake available.

Shoe Racks

Wire shelves offer the optimum combination of laminar flow and ventilation for the storage of cleanroom shoes. Rods and tabs run through the shelves to create cubbies for each pair of shoes. Optional snap-on plastic label holders are available for identification of each storage unit. Available finishes are chrome and electropolished stainless steel. Foot plates are included for fastening the unit to the floor. 14" width, ranging in lengths from 24" to 72", and up to 86" in height.



shoe rack



roll bag dispenser

Roll Bag Dispensers

Provides an effective means of dispensing rolls of bags or film. An easy way to establish protocol, by color of cleanroom waste, avoiding inadvertent mixing of non-compatible items. Standard unit consists of two 14" x 48" wire shelves, one 3-sided channel frame, eight removable dispensing bars and four 74" posts with 30" outrigger feet for stability. Dispensing bars are adjustable on 1" increments. Available in stainless steel or chrome finish. Unit measures 30" wide, 48" length, and 75" height. 30"-wide units available for mobile applications. Custom sizes also available.

Security Units

Security units range from 17¼" to 33¼" in width, 33¼" to 63¼" in length, and 69" height. Ideal for storing and transporting valuable materials. Security units are offered in chrome or electropolished stainless steel finish. Stationary and mobile units available.



full-size mobile security unit
—shown with optional
center shelf (sold
separately)

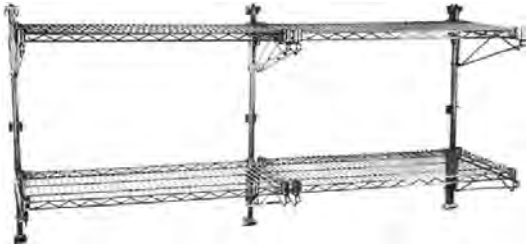

adjustable post
wire wall mount systems
(shown with standard wire shelves)

Adjustable Post Wire Wall Mount Shelf Systems

The adjustable wall mount provides wall storage and facilitates laminar flow. Use with standard wire shelves (*sold separately*). Designed to hold up to four tiers. The shelf widths range from 14" to 24" and the post height range from 14" to 63". Available in chrome and stainless steel.

AdjusTable® Work Surface Systems

Eagle's AdjusTable® System allows you to create work surfaces in the configuration of your choice. Each work surface system comes with four 33" posts and your choice of the following bases: two C-frames; two H-frames; one C-frame and one wire undershelf; or one H-frame and one wire undershelf. Work surfaces are available with solid or perforated tops, brushed or electropolished. Available sizes are 24" to 36" in width and 36" to 60" in length. Table bases are available in chrome or stainless steel. Optional keyboard, utility drawers, and casters are available.



AdjusTable® with H-frame and wire undershelf



C-frame AdjusTable® with
wire overshelf system



C-frame AdjusTable® with
cantilever overshelf system
and optional drawer

AdjusTable® Overshelf Systems

Eagle's AdjusTable® Overshelf System allows you to create work surfaces enhanced with two wire or cantilevered overshelves. Each work system comes with the two overshelves (two 29" posts come with wire overshelves only), two 33" front posts, two 63" rear posts, and your choice of the following table bases: two C-frames; two H-frames; one C-frame and one wire undershelf; or one H-frame and one wire undershelf. The available sizes are 24" to 36" width and 36" to 60" length. Work surfaces are available with solid or perforated tops, brushed or electropolished. Overshelves are offered in stainless steel or chrome finish. Optional keyboard, utility drawers, and casters are available.

Cleanroom Tables

Type 304 stainless steel tables are available with solid or perforated tops, brushed or electropolished finish. All perforated tops have $\frac{3}{4}$ " perforations on 1" centers, allowing for 40% laminar flow. Available in standard widths of 24", 30", and 36" and lengths from 36" to 96". Custom sizes available upon request. All cleanroom tables are alcohol-wiped and cleanroom bagged. Standard table bases are C-frame or H-frame in brushed or electropolished finish. Undershelves are available on request.



table with perforated top and H-frame



table with solid top and C-frame

Lab Workstations

Spec-Master® workstations feature a 14 or 16 gauge stainless steel top. All workstations are available with an adjustable stainless steel undershelf or tubular base. Left and right ends are turned down 90° providing a flat surface so tables can be placed end to end. Sound deadening insulation tape runs between hat channel and table top. All workstations feature our patented uni-lok® system which provides greater strength and a bullnose edge on front and rear (*without backslash*).



SE series



SE-BS series



STE series



STE-BS series

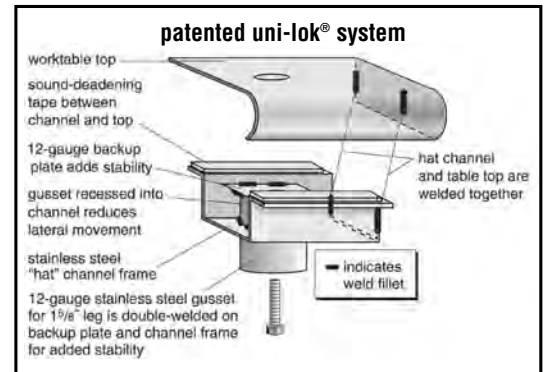

Mobile Table with Flex-Master® and Drawer

A totally flexible system for both new and existing operations when versatility is needed. A unique custom- style overshelf system utilizing standard components. Unsurpassed style, strength, performance, and flexibility. Unlimited combinations of shelves and utility racks to meet any need—imagine the possibilities! Customize your table with an appropriate sink.





mobile computer workstation with optional mouse shelf

Mobile Computer Workstations

Open wire workstation allows for laminar flow. Reduces moisture and dust build-up. Comes with standard keyboard drawer. Mouse shelf is optional. Available in chrome or stainless steel finish. 5" swivel casters (two with brake) with choice of resilient or polyurethane tread. 24" or 36" width, 24" or 36" length, 53 $\frac{3}{8}$ " overall height.

Stationary Workstations

Workstation with open wire construction offer 62% laminar flow with up to 800-lb. load-bearing capacity. Available in electropolished stainless steel or chrome finish. 24" width, and available in 36" or 48" length. Optional keyboard drawer available.



stationary workstation



mobile workstation shown with solid shelf and optional keyboard drawer

Mobile Workstations

Eagle's mobile workstations allow for easy relocation of stations as needed. Features four 5" poly stem casters (*two with brake*). Overshelves are height-adjustable in 1" increments for flexible and accurate placement without the use of tools. 24" width, and available in 36" or 48" length. Available in stainless steel or chrome finish. Optional keyboard drawer available.

FN Series Sinks

14 gauge stainless steel throughout. All bowls are 14" deep and have 5/8" radius corners, both vertical and horizontal. Legs feature adjustable crossbracing front-to-back and side-to-side to increase stability. Standard 10" backsplash and include a 1" upturn. Sinks come standard in one, two, three, or four compartments with or without drainboards.



3-bowl FN series sink with drainboards



314 series sink – shown with drainboards (faucet not included)

314 Series Sinks

Deep drawn sinks have a generous radius and are rectangular for maximum capacity. Legs are galvanized, 1 1/2" diameter and welded adjacent to sink bowl for maximum stability and support. Sinks come standard in one, two, three, or four compartments with or without drainboards.

Reinforced Laboratory Drop-In Sinks

Type 304 series stainless steel. Features faucet support plate, clip to reinforce faucet, and 1 1/2" basket drain. Available in one-, two- and three-compartment. Hole configurations offered in three options, depending on bowl size:

Option #1: 1 1/2"-diameter center hole for mixing faucet.

Option #2: Same as Option #1, plus 1 1/4"-diameter hole for eye/drench hose.

Option #3: Same as Option #2, plus 3/4"-diameter hole for DI faucet.

Option #1 available for all sink bowl sizes. Sinks with bowls 14" and longer offer all three options. On sinks with 14" to 16"-long bowls, holes are spaced on 6" centers. On sinks with bowls 18" and longer, holes are on 8" centers.

NEW



1-bowl sink with "Option #3"



2-bowl sink with "Option #1"



3-bowl sink with "Option #2"



3-bowl counter drop-in sink

Countertop Drop-In Self Rim Design Sinks

All units are 304 series stainless steel and come standard with mounting hardware, swivel faucet, and 1 1/2" basket drain. Available in one, two and three compartment.

Hand Sinks

Hand sinks are type 304 stainless steel all-welded construction. Deep-drawn, one-piece, seamless bowls. Models vary from the traditional hand sink with faucet to the electronic hand sink with soap and towel dispenser and hot water heater. Available in wall mount and pedestal type models.



HSA-10-FE hand sink

Stainless Steel Countertops



stainless steel countertops fabricated to drawings indicating backsplash height, raised edge and field condition requirements



welded or mechanical field joint as required



stainless steel island unit with three flush mount integral sinks

Countertops

- 16 or 14 gauge, type 304 or 316 stainless steel available.
- Standard front edge Square or Box Marine, unless otherwise specified. See *detail 1*.
- Standard height of back and end splashes is 4½", unless otherwise specified. See *detail 2 & 3*.
- Either a mechanical hairline seam or field welded joint available per your specifications. Maximum length without seam is 144". Length is reduced by 5½" for each end splash that may be required. Complete field welding and finishing services are available at additional expense.
- Fabricated sink bowls available in most any size and depth with single or multiple compartments. Specify your requirements: Type 304 or 316 stainless steel, drain size and location, overflow hole if required.
- For backsplash mounted faucets, splash will need to be at least 2" deep for plumbing access, holes for deck mounted faucets are typically centered 1¼" from the edge of sink bowl.
- Both L-shaped and U-shaped tops are available per your drawings.
 - Corners are mitered and factory welded.
 - Maximum size without field joint provisions fits 101"H x 96"W trailers for ground shipment.
- Countertops have galvanized steel reinforcing hat channels. Sound deadening tape is factory-installed. Top support options include NSF-listed sprayed latex sound deadening and marine grade plywood backing with white laminate facing.
- Standard packaging is wood reinforced cardboard and is included in the cost. Full crating available.

NOTE: Plumbing, electrical and refrigeration services available upon request, consult factory.

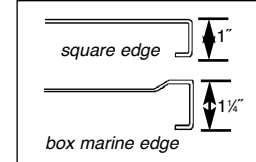

detail 1: edges

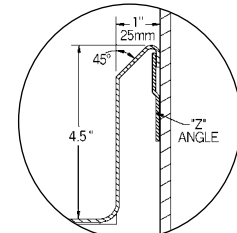

detail 2:
dimensions of a 4½" backsplash with 45° return

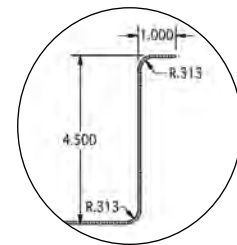

detail 3:
dimensions of a 4½" backsplash with 90° return

© 2013 Eagle Group.

Although every attempt has been made to ensure the accuracy of the data in this publication, we cannot be responsible for printing or typographical errors or omissions.



VALUE

QUALITY

RELIABILITY

Profit from the Eagle Advantage®

Corporate Headquarters • 100 Industrial Boulevard
Clayton, DE 19938-8903
• Phone: (302) 653-3000

Foodservice/SpecFAB® Divisions • Phone: (800) 441-8440
• Fax: (302) 653-2065

Material Handling Division • Phone: (800) 637-5100
• Fax: (302) 653-2065

www.eaglegrp.com



Rev 12/13 EG7003