

Foodservice Equipment • Material Handling, Healthcare & Cleanroom Equipment • Retail Display

Stainless Steel Counter Tops



*stainless steel counter top with rolled front edge,
4½" backsplash and integrated sink bowl*

Item #: _____
Model #: _____
Project #: _____
SIS #: _____

Counter Tops

- Constructed of 18-8 stainless steel type 304-16 or 14 gauge. Type 316 and others available when specified.
- Fabricated according to final drawings reflecting dimensions and details of field conditions.
- Mechanical hairline field joints when required. Field welding and polishing of field joints available at an added charge.
- All horizontal and vertical corners on counter tops and sinks are provided with a seamless sanitary cove or radius.

Sink Bowls

- Fabricated with same material as counter tops and meet specified dimensions.
- Standard Eagle deep-drawn sinks are available to reduce costs and lead time.

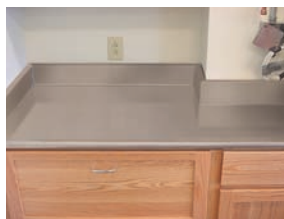

- Stainless steel counter tops fabricated to drawings indicating backsplash height, raised edge and field condition requirements.



- Welded or mechanical field joint as required.



- Stainless steel island unit with three flush mount integral sinks.

**DETAILED DRAWINGS WILL BE SUBMITTED FOR APPROVAL PRIOR TO FABRICATION.
PRICING INCLUDES THE COST OF PACKAGING.**

Spec sheets available for viewing, printing or downloading from our online literature library at www.eaglegrp.com

Stainless Steel Counter Tops

Counter tops fabricated to your exact specifications and field conditions. All fully TIG-welded with seams ground and polished into the parent metal.

Options include: Field joints, sink bowls, drain troughs, column cutouts, finishing of the back side of exposed back or end splashes, L-shapes, U-shapes, utility cutouts and holes, cup-sinks, provisions to mount fume hoods, and pass-through openings.

- 1) Choose from 16 or 14 gauge type 304 or 316 stainless steel.
- 2) Standard front edge Square or Box Marine, unless otherwise specified. *See detail 1.*
- 3) Standard height of back and end splashes is 4½", unless otherwise specified. *See detail 2 and 3.*

- 4) Either a mechanical hairline seam or field welded joint available per your specifications. Maximum length without seam is 144" length is reduced by 5½" for each end splash that may be required.

*Complete field welding and finishing services are available at additional expense.

- 5) Fabricated sink bowls available in most any size and depth with single or multiple compartments. Specify your requirements: Type 304 or 316 stainless steel, drain size and location, overflow hole if required.

- 6) For backsplash mounted faucets, splash will need to be at least 2" deep for plumbing access, holes for deck mounted faucets are typically centered 1½" from the edge of sink bowl.

- 7) Both L-shaped and U-shaped tops are available per your drawings.
 - Corners are mitered and factory welded.
 - Maximum size without field joint provisions is 96" x 96" to fit into standard trailer for ground shipment.

- 8) Counter tops have galvanized steel reinforcing hat channels. Sound deadening tape is factory installed. Top support options include; NSF listed sprayed latex sound deadening, and marine grade plywood backing with white laminate facing.

- 9) Standard packaging is wood reinforced cardboard and is included in the cost. Should full crating be required, it to will be included in the cost.

NOTE: Plumbing, electrical and refrigeration services available upon request, consult factory.

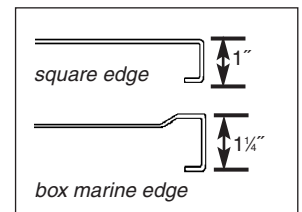

detail 1: edges

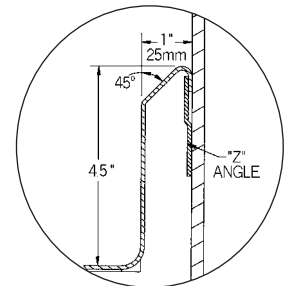

**detail 2:
dimensions of a 4½" back-
splash with a 45° return**

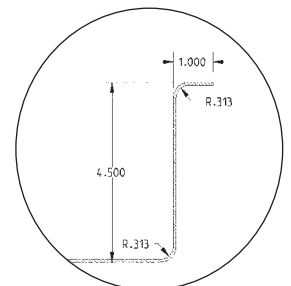

**detail 3:
dimensions of a 4½" back-
splash with a 90° return**

Integral Sink Bowls

Fabricated Sink Bowls - facilitates construction of any size bowl specified. Bowls have a 5/8" radius corners, both vertical and horizontal. Available in 14 gauge 304 or 316 stainless. Basket-type waste drains are included to fit 3 1/2" opening. *See detail 4.*

Drawn Sink Bowls - drawn from 18 gauge 304 stainless to provide a cost effective option to a fabricated bowl. Available in single, double, and triple bowl configurations. *See details 5 & 6.*

Mounting Options

Both fabricated and deep drawn bowls can be recessed, or flush mounted to the countertop.

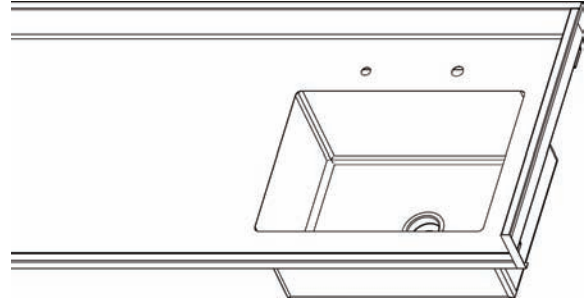

detail 4: fabricated style sink - flush mounted

Flush Mount Sink Bowls - bowls are welded flush to the top surface of the countertop. *See detail 4.*

Recessed Sink Bowls - Bowls are mounted with a 1/2" deep welded recess that is 2" longer and wider than the bowl. Optional stainless steel or poly covers allow it to become part of the work surface. *See detail 5 & 6.*

Lower Cost Drawn Bowl Sizes

w x l	bowl depth
14" x 10"	5"
14" x 10"	9 1/2"
14" x 12"	9 1/2"
16" x 14"	9 1/2"
19" x 16"	8"
19" x 16"	13 1/2"
24" x 18"	13 1/2"

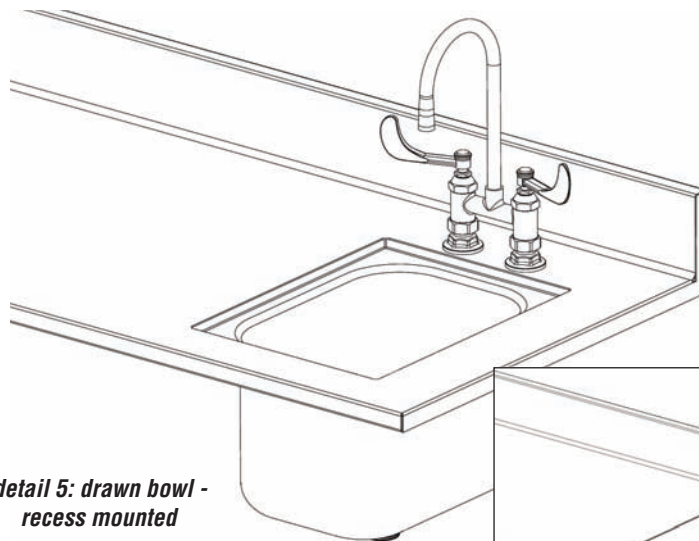

detail 5: drawn bowl - recess mounted

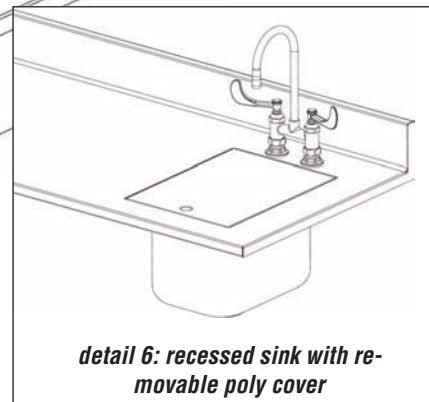

detail 6: recessed sink with removable poly cover

Stainless Steel Counter Top Quick-Quote

304 Stainless Steel #4 Finish Countertops with 4½" high x 1" Backsplash - List Price ea.

		with Marine-Grade Plywood	with Galvanized Hat Channels	with Stainless Steel Hat Channels
length		list	list	list
24"	610	1037	975	1026
30"	762	1059	996	1048
36"	914	1082	1016	1070
42"	1067	1130	1063	1118
48"	1219	1179	1109	1167
54"	1372	1228	1154	1215
60"	1524	1278	1201	1264
66"	1676	1327	1248	1313
72"	1829	1459	1293	1362
78"	1981	1510	1339	1410
84"	2134	1561	1386	1459
90"	2286	1614	1433	1508
96"	2438	1662	1478	1557
102"	2591	1713	1604	1689
108"	2743	1764	1730	1822
114"	2896	1814	1777	1871
120"	3048	1864	1824	1920
126"	3200	1915	1870	1968
132"	3353	1966	1915	2016
138"	3505	2016	1962	2065
144"	3658	2067	2009	2114

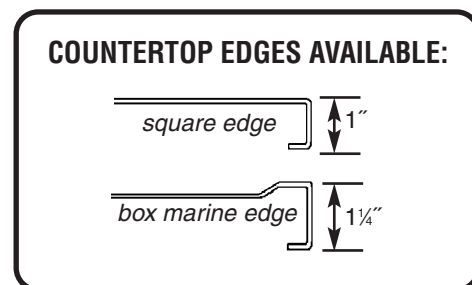

Other length counter tops will be priced and built to dimensions furnished on submitted drawing.

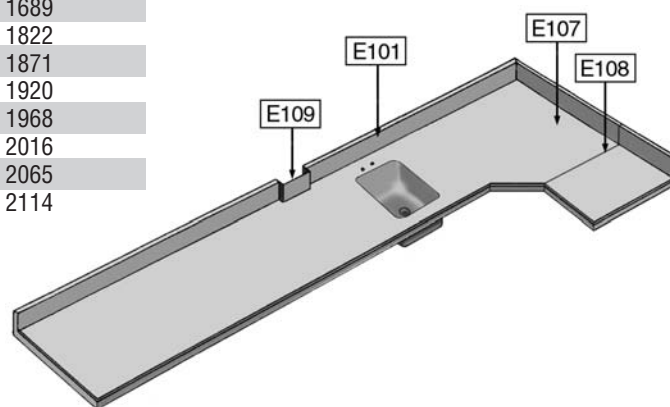

Options and Accessories

model #	description	list
E101	10" (254mm) high backsplash, per linear foot	50
E107	90° corner	1193
E108	Welded field joint	233
E109	Cutout for pipes, columns	583
E37	NSF sprayed-on latex sound deadening - up to 12 (3658mm)	596
E37A	for each additional ft.	36
Type 316 S/S	Add per countertop/item	45%

Optional Drawn bowl sinks - complete with faucet & basket drain

model #	description	list
E20	14" x 10" x 9½" (356 x 254 x 241mm)	943
E21	16" x 14" x 9½" (406 x 356 x 241mm)	991
E22	20" x 16" x 8" (508 x 406 x 203mm)	1057
E23	20" x 16" x 14" (508 x 406 x 356mm)	1172
E24	20" x 18" x 14" (508 x 457 x 356mm)	1285
E24A	20" x 20" x 14" (508 x 508 x 356mm)	1294
E25	24" x 24" x 14" (610 x 610 x 356mm)	1752

Request an Eagle Catalog or 2010 Price List for additional products:

- Wire Shelving & Shelving Systems • Tables • Carts • Cleanroom Equipment • Fume Hood Components • Cabinets • Work Stations • Scullery Sinks • Wash Sinks

The Eagle Advantage™ begins right here in our state of the art manufacturing facility - with 14 acres under one roof, where the most comprehensive broadline product offering in the industry takes shape. This all-inclusive design and production capability offers distinct advantages to our customers. Streamlined ordering and shipping substantially reduce freight, receiving, installation and administrative costs.



Profit from the Eagle Advantage®

100 Industrial Boulevard • Clayton, DE
 19938-8903 USA • Fax: (302) 653-2065
FDSRV Division: Phone (800) 441-8440
MHC Division: Phone (800) 637-5100
SpecFAB® Division: Phone: (800) 441-8440
 Fax: (302) 653-3091 • E-mail: specfab@eaglegrp.com



www.eaglegrp.com

© 2010 Eagle Group. Although every attempt has been made to ensure the accuracy of the data in this publication, we cannot be responsible for printing or typographical errors or omissions. Due to an ongoing product improvement program, specifications, dimensions & prices are subject to change without notice.