

Utility Cart

ASSEMBLY INSTRUCTIONS

CAUTION

INSPECT CONTENTS IMMEDIATELY AND FILE CLAIM WITH DELIVERING CARRIER FOR ANY DAMAGE.
SAVE YOUR BOX AND ALL PACKING MATERIALS.
YOU ARE RESPONSIBLE FOR DAMAGE TO YOUR UNIT IF RETURNED IMPROPERLY PACKED.

Parts List

#	qty	description
#1	2	"U" handle assembly
#2	*	wire shelves
#3	4	donut bumpers
#4	4	stem casters
#5	*	split sleeves (pack of four)
#6	4	double-threaded bolt **

* Quantity will vary per order.
** For carts with zinc or chrome finish only.

PLEASE READ BEFORE ASSEMBLY...

If your cart is plated in zinc or chrome, you must assemble the "U"-handles PRIOR TO cart assembly. Assemble as shown.

If your cart is stainless steel, skip this and proceed to Step 1.

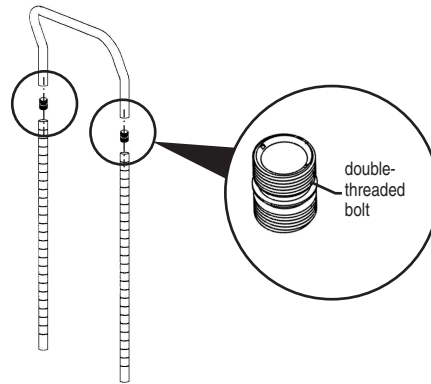

Step 1 - Mount top shelf.

- Slide shelf toward top of "U" handle legs.
- Attach split sleeves to top groove of "U" handle legs (see figure 1a). The wider part of the taper goes toward the bottom.
- Slide shelf down onto split sleeves (see figure 1b).

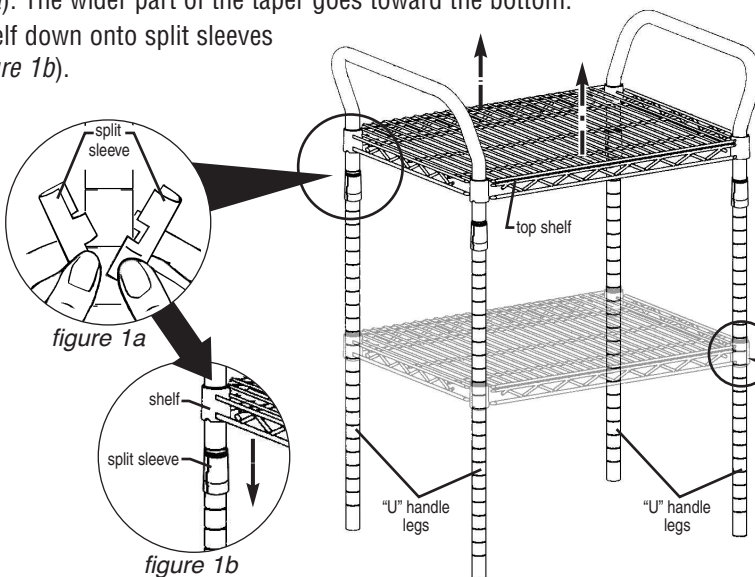

Before continuing, please note:

Step 2 pertains to carts with three shelves. If your cart has only two shelves, skip Step 2 and proceed to Step 3.

Step 2 - Mount mid shelf.

- Slide shelf toward top of "U" handle legs.
- Attach split sleeves (see figure 1a) to "U" handle legs at desired height.
- Slide shelf down onto split sleeves (see figure 2).

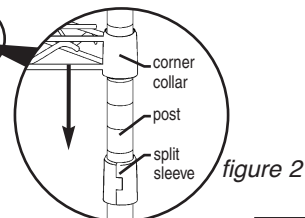

(continued on back page)

EG9830 Revised 04/14

Utility Cart

ASSEMBLY INSTRUCTIONS

Step 3 - Mount bottom shelf.

- Slide shelf toward top of "U" handle legs.
- Attach split sleeves to bottom groove of "U" handle legs (see *figure 3a*).
- Slide shelf down onto split sleeves (see *figure 3b*).

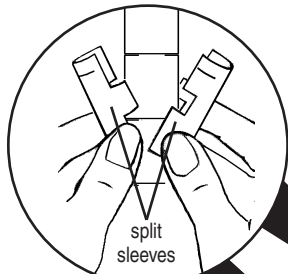

figure 3a

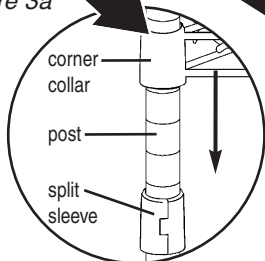
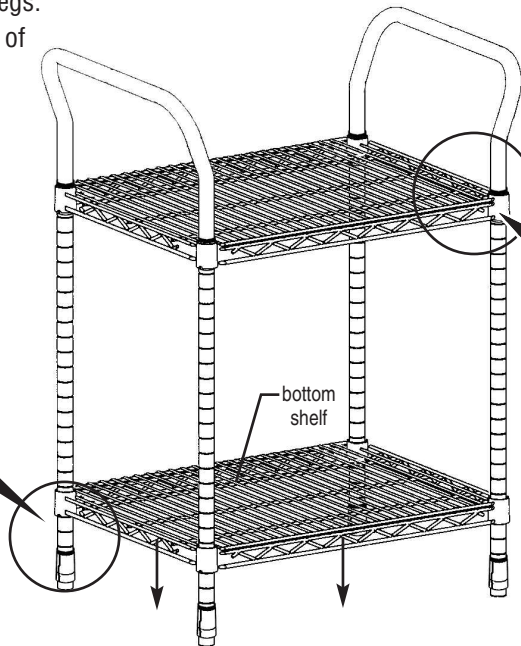

figure 3b



Step 4: Securely seat all shelves.

- On each shelf, lay a board diagonally across the front and side wire shelf trusses, and firmly seat shelf onto split sleeves with a rubber mallet (see *figure 4*).
- Do NOT hammer directly on shelf.
- Repeat on remaining corners.

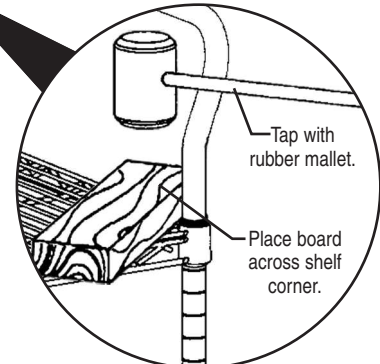
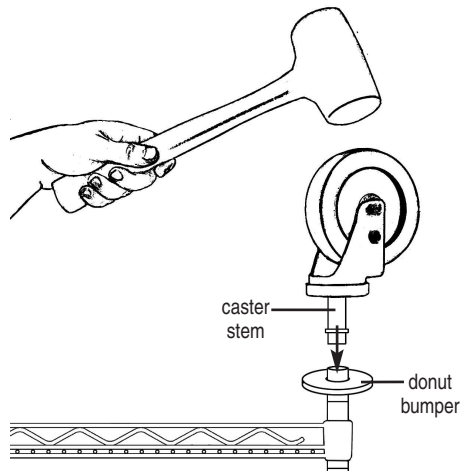

figure 4

Step 5 - Secure casters to unit.

- Place donut bumpers onto ends of "U" handle legs.
- Place caster stems into bottom of "U" handle legs and drive caster, using a hammer or mallet (several solid blows are usually required).



Assembly is complete.

(End)