

# Wafer Cassette Transport Cart

Item #:	_____
Model #:	_____
Project #:	_____
SIS #:	_____

Optional Accessories	Model #	Qty.



*wafer cassette transport cart*

- ◆ Designed to optimize maneuverability in restricted-space critical environments.
- ◆ Offers significant cost savings and improved efficiencies over heavier, bulkier carts.
- ◆ Features a specially-designed wafer cassette shelf that holds wafers securely, and provides laminar flow.
- ◆ 40" shelf height with an adjustable-height push handle for better ergonomics and user-friendly operation.
- ◆ "Softie™" plate casters provide excellent vibration dampening without the black rubber tread associated with traditional pneumatic casters.

Spec sheets available for viewing, printing or downloading from our online literature library at [www.eaglegrp.com](http://www.eaglegrp.com)

For custom configuration or fabrication needs, contact our **SpecFAB Division**.  
Phone: (302) 653-3000. FAX: (302) 653-3091.  
E-mail: [specfab@eaglegrp.com](mailto:specfab@eaglegrp.com)

## Wafer Cassette Transport Cart

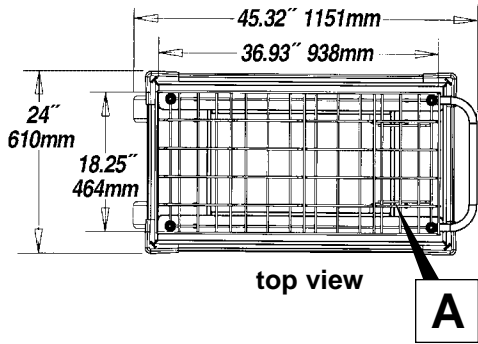

top view

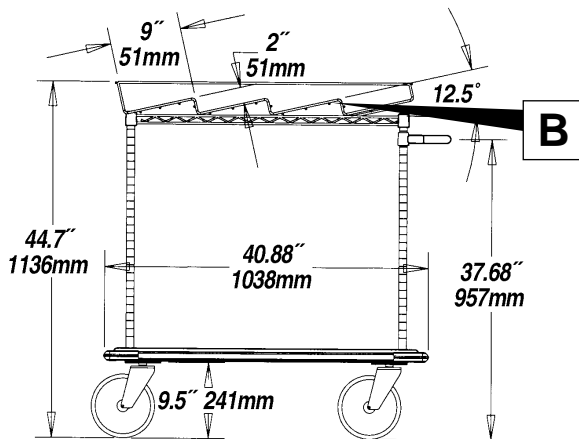

side view

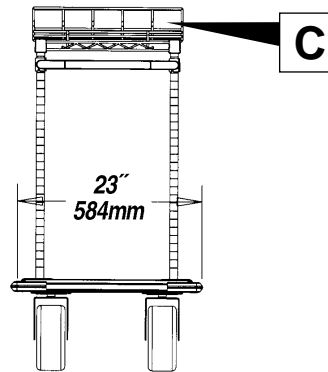

end view

- **Shelf** — See below for shelf specifications.
- **Push handle** — Adjustable height.
- **Posts** — 1" (25mm)-diameter x 30" (762mm) height, 16 gauge stainless steel, grooved in 1" increments.
- **Dolly frame** — 18" x 36" (457 x 914mm). 14 gauge type 304 stainless steel, with bumpers.
- **Casters** — 8" (203mm)-diameter swivel stainless steel plate casters (two with brake). Caster wheel constructed of 50 durometer treadless poly to reduce vibration transfer during transport.

width x length	weight	model
in. mm	lbs. kg	
18" x 36" 457 x 914	69 31.3	WTC1836

## Wafer Cassette Transport Wire Shelf

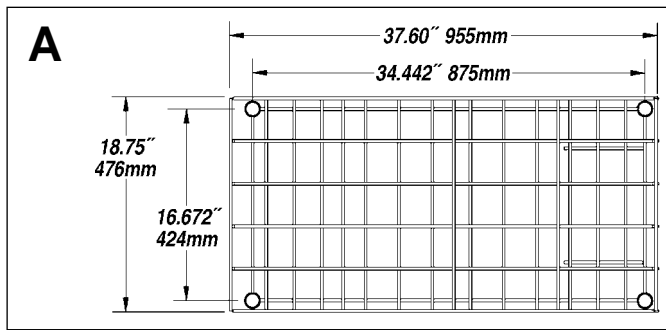

top view

- **Shelf** — Constructed of .25"-diameter electropolished wire with four stainless steel collars. Collar centerlines allow shelf to be mounted with any 18" x 36" (457 x 914mm) Eagle wire shelf or solid shelf. 2" (51mm)-high perimeter wire holds cases securely during transport.
- **Shelf capacity** — Holds up to 8 cassette cases with each case tilted 12.5 degrees.

width x length	weight	model
in. mm	lbs. kg	
18" x 36" 457 x 914	15 6.8	A209931

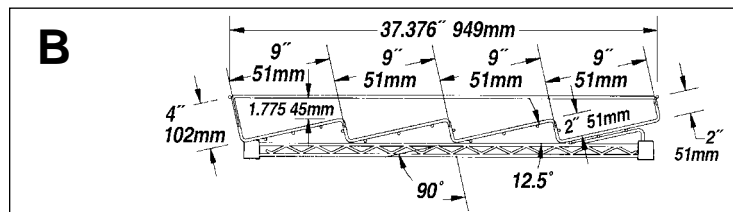

side view

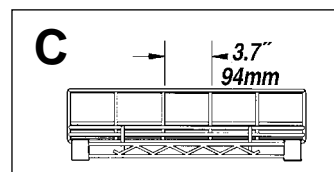

end view